

eclipse II

High Frequency

Conventional Industrial
Battery Charger



Setting the Industry Standard for High Frequency Performance

- ⚡ **The AC characteristics of the Eclipse II series of chargers are ideal considering today's rising energy costs**
- ⚡ **High efficiency charging, as high as 93%, reduces energy costs**
- ⚡ **High power factor >.95 for low installation costs**
- ⚡ **Multi-voltage and Multi-ampere hour operation**
- ⚡ **100% rated to recharge fully discharged batteries in 8 hours or less**
- ⚡ **Save on transportation costs and mechanical installation with light weight and small size**
- ⚡ **Adapts to all battery types and applications with user selectable charge algorithms**
- ⚡ **Available in 480 VAC only and 480/600 VAC**
- ⚡ **All chargers are UL and cUL listed**

AMETEK[®]
PRESTOLITE POWER



Made in America

eclipse II



Inside View



Side View

Side panel is removable for easy access to components



Eclipse II

The Eclipse II series of chargers set a new industry standard for efficiency, accuracy, and flexibility. The charger uses advanced IGBT high frequency power conversion circuitry to provide efficient dependable service. Designed to recharge any 100% discharged flooded lead-acid battery within the charger's rated capacity in 8 hours or less. The Eclipse II is engineered for energy efficient charging in one of the most compact packages available on the market today. With the Eclipse II, the battery determines its own charge cycle rate based on its state of discharge. The Eclipse II constantly monitors the battery's condition to provide the optimum charge with minimal temperature rise and it completes the charge at the proper current regardless of battery age, battery type, or electrolyte temperature.

Efficient, Low Cost Operation

The advanced design of the Eclipse II is extremely efficient at 93%, converting AC power to usable DC power with the minimum possible impact on the utility grid. The >.95 power factor minimizes AC amp draw and thereby reduces installation costs.

EC2000 Control

The new EC2000 control is nearly identical in functionality and programmability to AMETEK's popular UC2000 used in the Ultra product line. With a 40 character, alphanumeric LCD display, easy to read information is always available to follow the charger's status. In addition, 4 bright LED's provide charge status at a glance and the sealed membrane keypad allows for easy customer interface.

Energy Saving Features

Further enhance energy savings by utilizing the EC2000's programmable start modes. Using the **Delayed** or **Time-of-Day** start modes of the EC2000 to charge your batteries during off-peak hours can yield up to 50% in additional energy cost saving. The EC2000 also offers **Time-of-Day Block-Out** to lower utility bills and reduce peak demand by blocking out a period of charging time on one or more chargers.

Automatic or Manual Equalize Operation

All Eclipse II chargers are shipped with Automatic Equalize enabled to ensure that your batteries routinely receive an equalize charge of three hours beyond the normal charger termination. Auto Equalize can be set for one of two options, Number of Cycles, or Day of Week.

When any automatic equalize function is selected, the equalize button on the keyboard is disabled to prevent unnecessary equalize charges. The ability to automatically equalize batteries provides an exact schedule of equalize charges for better battery maintenance and longer battery life.

Control Equalization Cycles

When an AMETEK BID is attached to the battery, it tracks and records completed charge cycles. When the battery is connected to the charger, the Eclipse II reads the BID information to determine how many charge cycles have been completed since it was last equalized. When the number of completed cycles matches the user selected equalize interval, the charger will equalize that battery. This ensures that each battery is equalized at the intervals selected by the customer regardless of which charger is connected.

Battery Cool Down

Battery cool down allows the battery to cool down before use, which allows for increased control of battery rotation, resulting in increased battery efficiency and longer life. Battery cool down can be programmed from the EC2000 keypad from 0-8 hours in one hour increments. After the recharge is complete, the display will read "battery cool down" until the predetermined cool down period has ended, at which time the charge complete LED is illuminated.

Regulation

The Eclipse II is designed to hold the finish voltage rate to within +/-1% and the finish current to within +/-2% over a wide range of line voltage variations.

Cabinet Design

Flexible cabinet design allows charger to be mounted on a shelf or the wall without additional brackets. The legs are simply removed from the bottom of the charger and bolted to the rear panel to convert the charger from shelf mounting to wall mounting. Chargers can be stacked up to three high.

Quiet Fan Cooling

The Eclipse II utilizes an advanced fan design to cool the electronics, extending life while providing low sound levels for quiet operation.

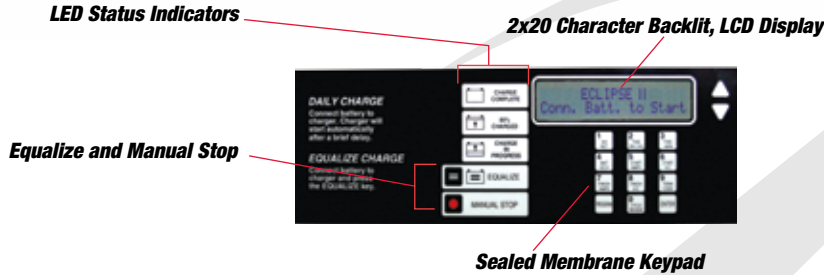

Warranty, 10-3-1

For the original purchaser, repair costs are minimized through a 10 year warranty on power transformers, plus 3 years on electronic PC boards, and 1 year on other components.

Prevent Overcharging

Back-up timers protect your batteries from overcharging by shutting the charger off in the event that the battery does not reach 80% charged in 9 hours, or does not reach charge complete within 4 hours of reaching the 80% charged point. The charger also monitors the ampere hours returned and if the ampere hours returned exceed the rated ampere hour capacity by 125%, the charger will shutdown, protecting your battery from harmful overcharging. (150% on equalize cycles.)

Charge Cycle Archive

The Eclipse II will collect and save 21 items of charge cycle information for the last 500 charge cycles. This valuable information can then be reviewed manually from the front panel, or it can also be downloaded wirelessly using our DataLink² system.

Operating Modes

Multi-cell: automatically matches output voltage to battery

Fixed-cell: set for specific battery voltage, rejects others

BID Mode: information programmed in BID determines charger operation

Timer Start: operated as a manual timer for maintenance and shop charging

Charges all Battery Types

The precisely controlled output of the Eclipse II allows this charger to charge all battery types. It charges flooded lead acid batteries as well as Gel Cell and AGM with just a few keypad entries to change the programming. In addition to pre-programmed charging algorithms, there is a programmable custom curve available for special application or future battery developments.

Battery Identification Module



The functionality of the Eclipse II charger can be greatly enhanced through the addition of the optional Battery Identification Module, BID. The BID is programmed with

battery information including rated AH capacity, rated voltage, battery type and more.

Batteries with BIDs will be automatically recognized by the charger, allowing the charger to charge at the proper voltage and current levels for the type of battery connected. The BID eliminates any manual charger settings.

BID with Ampere-Hour Accumulator



When equipped, a battery with an ampere-hour accumulator BID will transmit to the EC2000 control, the updated AH data. The accumulated AHs

for both charge and discharge cycles are stored in the BID along with the lifetime average battery temperature, and is readable from the EC2000 control and through the DataLink² System.

BID with Electrolyte Sensor



The addition of an electrolyte sensor to the standard BID allows the charger to sense when the connected battery needs to be checked for electrolyte levels. At charge

complete, the BID will send a signal to the charger that the electrolyte level is low, and the control will display a message instructing the operator to check the battery.

Wireless Fleet Management System

The Eclipse II is Datalink² compatible. Datalink² gives you the opportunity to monitor battery usage and identify bad situations before they become problems that lead to down time.

Datalink² greatly enhances the ability to collect charge and discharge data from the charger. The transfer of data occurs wirelessly utilizing our proprietary wireless network in combination with a powerful transceiver. Typical communication range is 1,500 ft in a normal operating environment and with communication between chargers, this range is doubled to a 3,000 ft radius. The actual range in your facility can vary greatly based on numerous factors. It is not necessary for the system to be integrated into the customer's network.

Dimensions

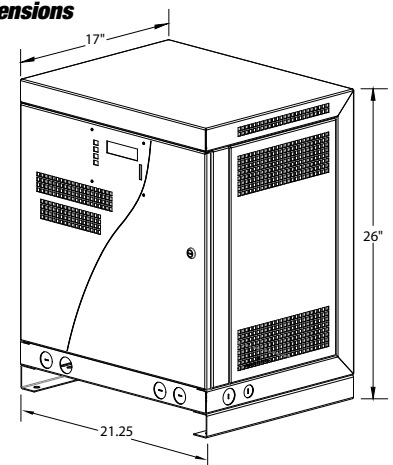

ECLIPSE II 480VAC ONLY MODELS

Number Battery Cells	Model Number	Battery Amp-Hour Capacity for 8 Hrs.	DC Output Amps	Phase	AC Input Amps at 480 VAC 60 HZ-3 ph	Approx. Weight (lbs.)
Three Phase 100%						
6,9,12	500EC3-12S	500	82	3	3.3	101
6,9,12	600EC3-12S	600	98	3	3.9	101
6,9,12	800EC3-12S	800	130	3	5.2	106
6,9,12	925EC3-12S	925	151	3	6.0	106
6,9,12	1050EC3-12S	1050	171	3	6.9	106
6,9,12,18	600EC3-18S	600	98	3	5.9	101
6,9,12,18	800EC3-18S	800	130	3	7.8	106
6,9,12,18	925EC3-18S	925	151	3	9.1	106
6,9,12,18	1050EC3-18S	1050	171	3	10.3	106
6,9,12,18	1200EC3-18S	1200	196	3	11.8	110
6,9,12,18	1400EC3-18S	1400	228	3	13.7	110
6,9,12,18	1600EC3-18D	1600	261	3	15.7	134
6,9,12,18,24	500EC3-24S	500	82	3	6.5	101
6,9,12,18,24	600EC3-24S	600	98	3	7.8	101
6,9,12,18,24	800EC3-24S	800	130	3	10.4	106
6,9,12,18,24	925EC3-24S	925	151	3	12.1	106
6,9,12,18,24	1050EC3-24S	1050	171	3	13.7	106
6,9,12,18,24	1200EC3-24D	1200	196	3	15.7	130
6,9,12,18,24	1400EC3-24D	1400	228	3	18.3	130
6,9,12,18,24	1600EC3-24D	1600	261	3	20.9	134
6,9,12,18,24,36,40**	375EC3-40S	375	61	3	8.2	98
6,9,12,18,24,36,40**	500EC3-40S	500	82	3	10.9	101
6,9,12,18,24,36,40**	600EC3-40S	600	98	3	13.1	101
6,9,12,18,24,36,40**	800EC3-40D	800	130	3	17.4	130
6,9,12,18,24,36,40**	925EC3-40D	925	151	3	20.1	130
6,9,12,18,24,36,40**	1150EC3-40D	1150	187	3	25.0	134

ECLIPSE II 480/600VAC MODELS

Number Battery Cells	Model Number	Battery Amp-Hour Capacity for 8 Hrs.	DC Output Amps	Phase	AC Input Amps at 480 VAC 60 HZ-3 ph	AC Input Amps at 600 VAC 60 HZ-3 ph	Approx. Weight (lbs.)
Three Phase 100%							
6,9,12	500EC3-12SC	500	82	3	3.3	2.6	101
6,9,12	600EC3-12SC	600	98	3	3.9	3.1	101
6,9,12	800EC3-12SC	800	130	3	5.2	4.2	106
6,9,12	925EC3-12SC	925	151	3	6.0	4.8	106
6,9,12	1050EC3-12SC	1050	171	3	6.9	5.5	106
6,9,12,18	600EC3-18SC	600	98	3	5.9	4.8	101
6,9,12,18	800EC3-18SC	800	130	3	7.8	6.2	106
6,9,12,18	925EC3-18SC	925	151	3	9.1	7.3	106
6,9,12,18	1050EC3-18SC	1050	171	3	10.3	8.2	106
6,9,12,18	1200EC3-18SC	1200	196	3	11.8	9.4	110
6,9,12,18	1400EC3-18SC	1400	228	3	13.7	11.0	110
6,9,12,18	1600EC3-18DC	1600	261	3	15.7	12.6	134
6,9,12,18,24	500EC3-24SC	500	82	3	6.5	5.2	101
6,9,12,18,24	600EC3-24SC	600	98	3	7.8	6.2	101
6,9,12,18,24	800EC3-24SC	800	130	3	10.4	8.3	106
6,9,12,18,24	925EC3-24SC	925	151	3	12.1	9.7	106
6,9,12,18,24	1050EC3-24SC	1050	171	3	13.7	11.0	106
6,9,12,18,24	1200EC3-24DC	1200	196	3	15.7	12.6	130
6,9,12,18,24	1400EC3-24DC	1400	228	3	18.3	14.6	130
6,9,12,18,24	1600EC3-24DC	1600	261	3	20.9	16.7	134
6,9,12,18,24,36,40**	375EC3-40SC	375	61	3	8.2	6.6	98
6,9,12,18,24,36,40**	500EC3-40SC	500	82	3	10.9	8.7	101
6,9,12,18,24,36,40**	600EC3-40SC	600	98	3	13.1	10.5	101
6,9,12,18,24,36,40**	800EC3-40DC	800	130	3	17.4	13.9	130
6,9,12,18,24,36,40**	925EC3-40DC	925	151	3	20.1	16.1	130
6,9,12,18,24,36,40**	1150EC3-40DC	1150	187	3	25.0	20.0	134

** Control does not auto select between 36 and 40 cell



Manufactured by AMETEK PRESTOLITE POWER

Phone: 800.367.2002 • Fax: 800.654.4024
www.prestolitepower.com

Distributed By:

Because we continually improve our products, specifications are subject to change without notice.
©2013, AMETEK, Inc. Prestolite Power, Troy, Ohio
Data Sheet: 1606 05/13 5M Printed in U.S.A.
Replaces 10/11

